

Hyperframe

2048 Superframes / Period = 3 h 28 min 53 s 760 ms

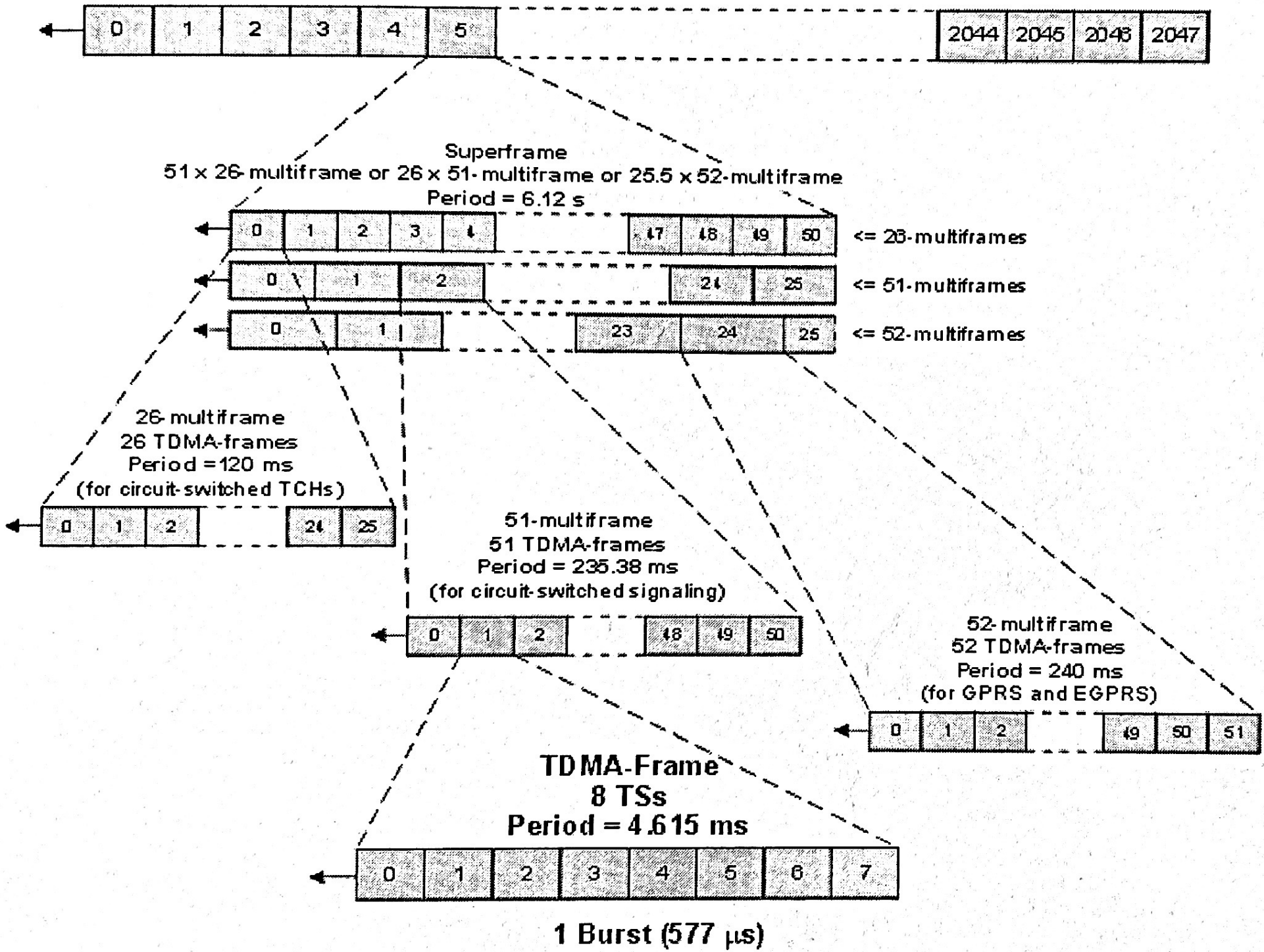

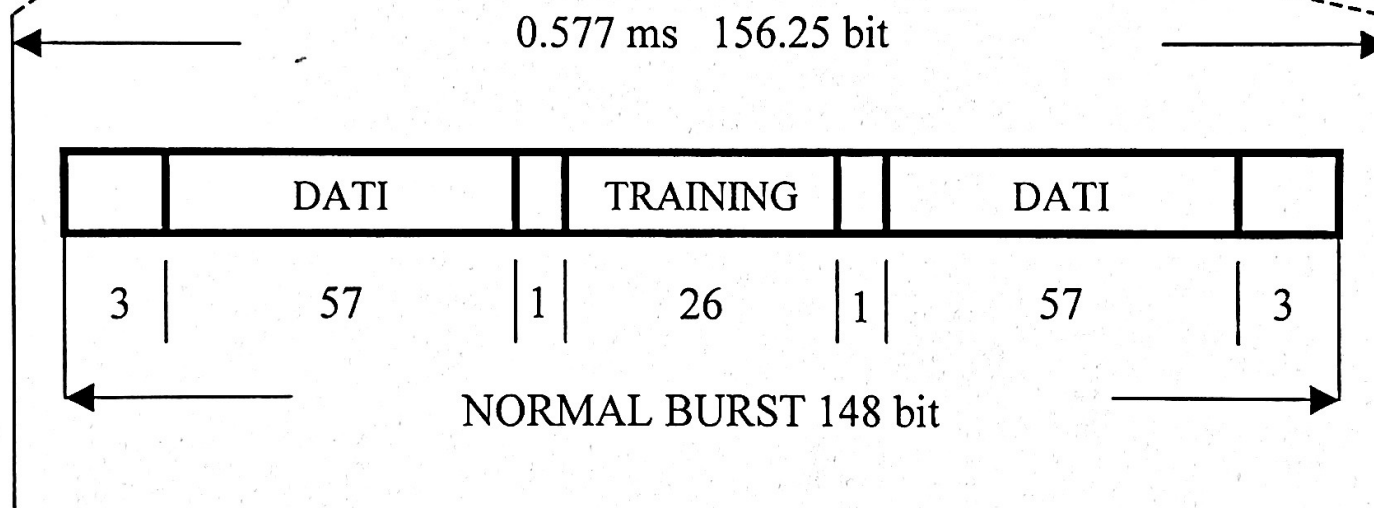

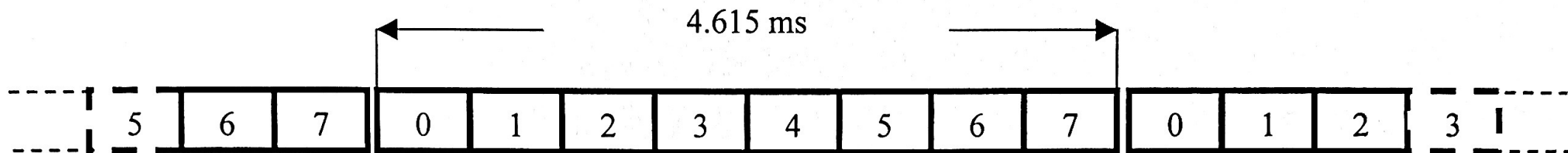
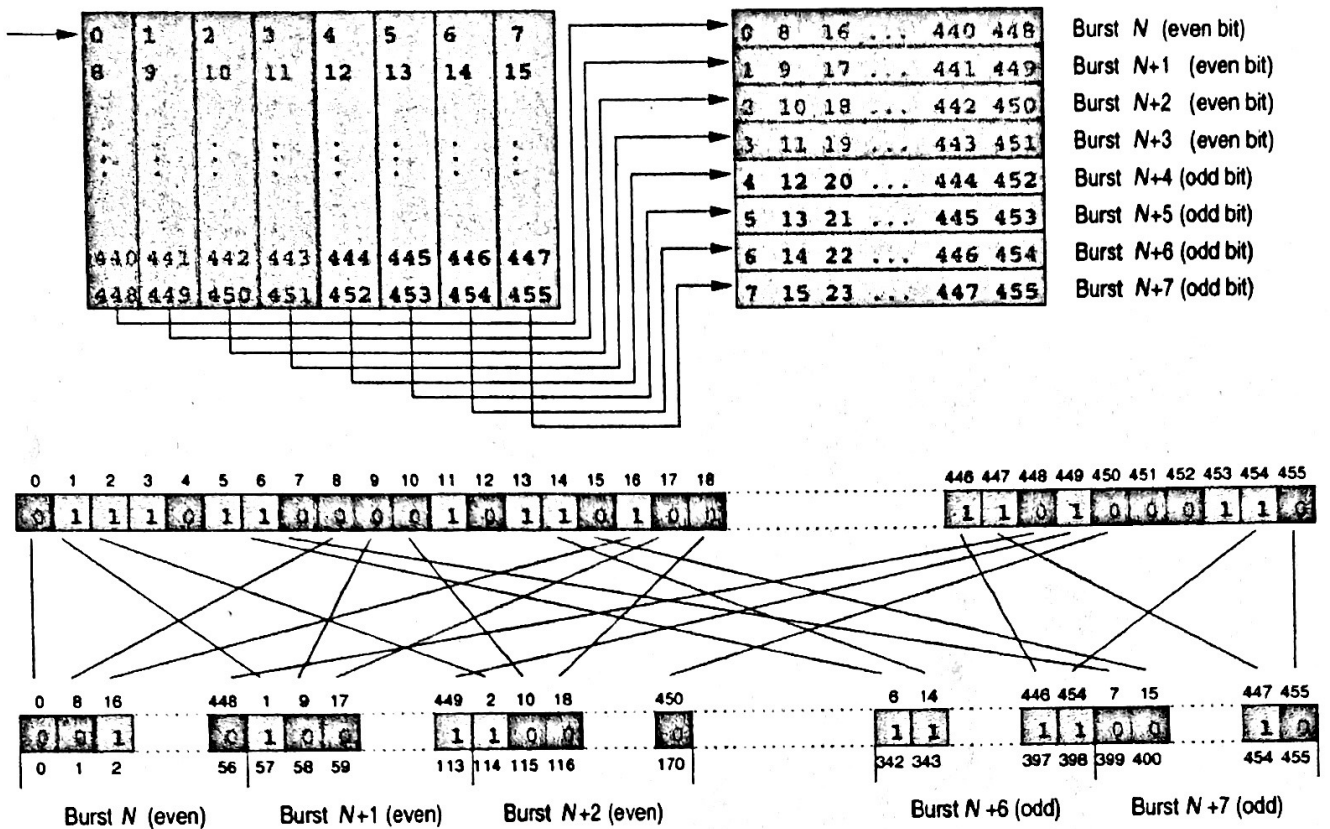

Figure 3.25: Example of interleaving

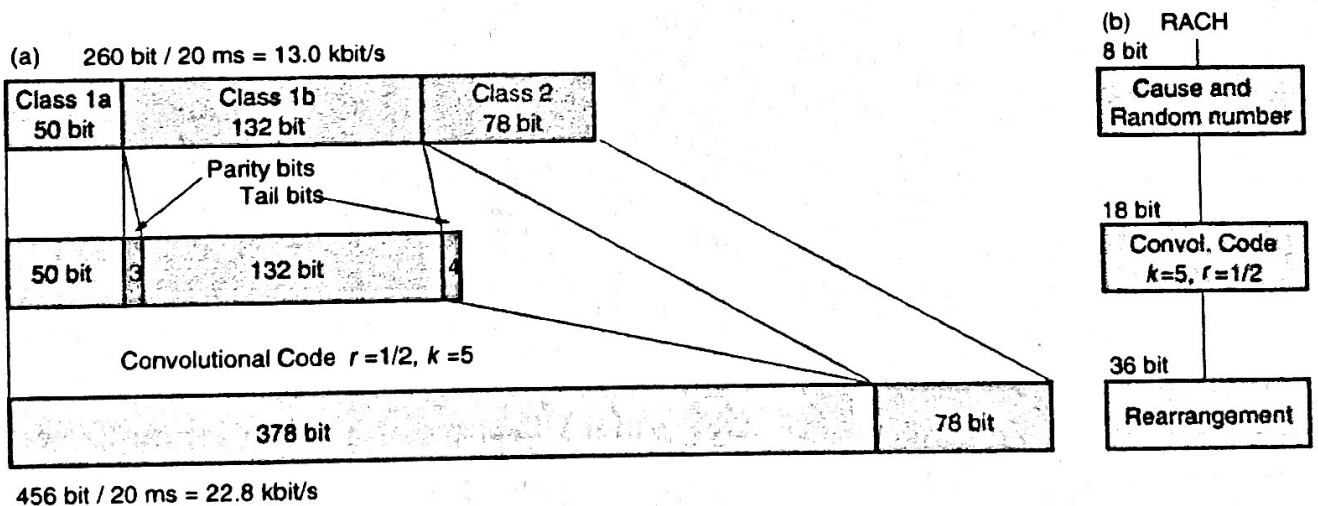

Figure 3.26: Channel coding for (a) speech transmission and (b) signalling

slots of a logical channel. An interleaving of 4 is continuously applied to the signalling channels because messages are too short and otherwise too many slots would be occupied.

3.3.7.2 Speech Coding for Radio Transmission

In line with GSM goals on frequency economy, the transmission rate was not to exceed a value of approx. 16 kbit/s. The speech codec RPE-LTP was

Canali logici: Schema riassuntivo

GSM Channels

